



**Elmbridge Borough Council – Lot 1 West Molesey Rec**  
**KOMPAN Tender Response**

KOMPAN Opp Ref: EN350520  
KOMPAN Quote Ref: SQ292049  
KOMPAN Ltd, Shirwell Crescent, Furzton  
Lake, Milton Keynes, MK4 1GA



# Contents

Play Area Design	Page 3
Product Sheets	Page 6
Vandalism (1.2.3.1) & (2.12)	Page 27
Colour Options (2.5)	Page 30







**Play Area Design**



Universal Design.  
This playground has been designed  
for everyone to use, together.



WOW!  
Texmade  
Textile Recycled  
Posts

Awesome  
Spinning  
Rocket

Existing Toddler  
Zone Location &  
Sand Pit



Inclusive  
Communication  
Board

Hammocks

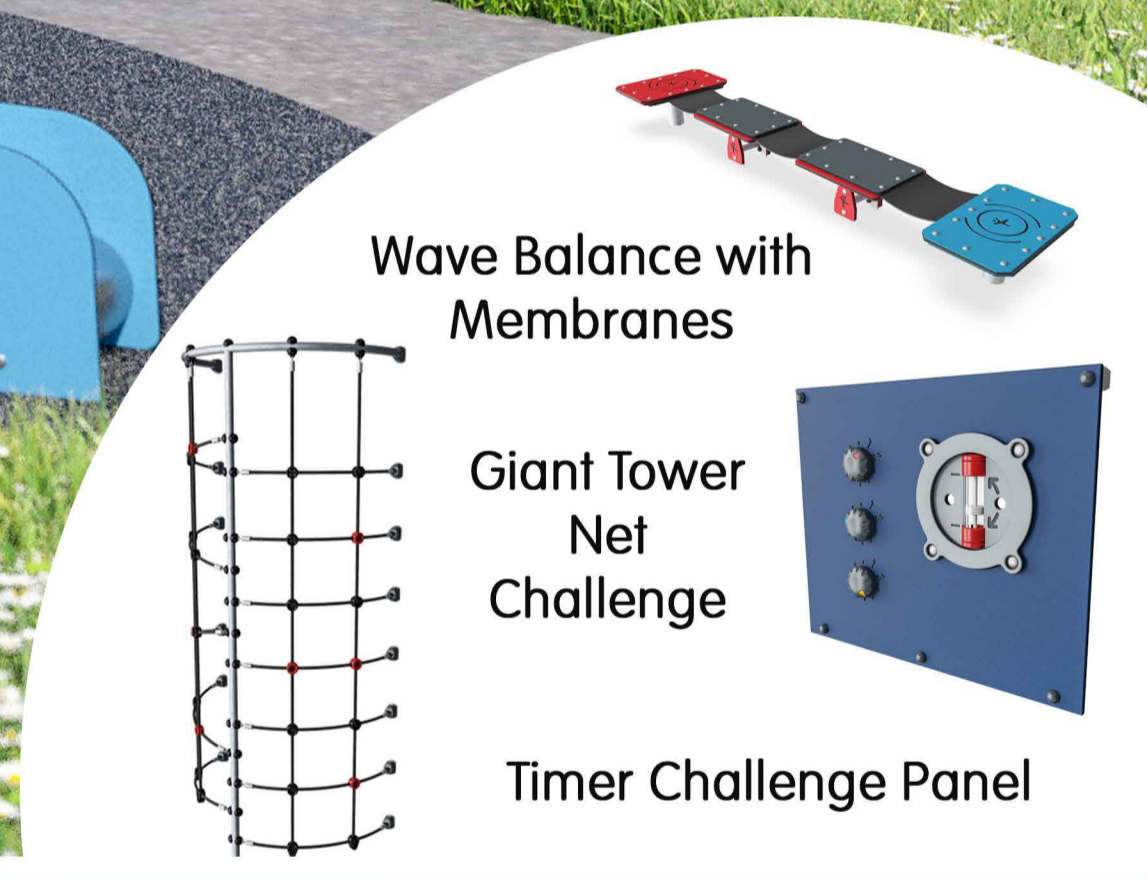

# West Molesey Junior Zone

Elmbridge Borough Council

Toddler zone equipment and sand pit, to remain in situ.  
Exciting NEW Junior Zone only shown in 3D visual

Choose Green?  
We choose for you!

All of our HDPE products  
are made from **95%**  
post consumer waste!  
**WOW!**



2x Fun Slides

AGE  
**6-12**  
RANGE



SCAN ME  
to view our green  
journey brochure



DRAWN BY: RB | NOTE: PLEASE DO NOT SCALE FROM THIS DRAWING. THIS DRAWING IS NOT TO SCALE. THIS IS PURELY AN ARTIST'S IMPRESSION.



# WEST MOLESEY RECREATION GROUND - LOT 1

ELMBRIDGE BOROUGH COUNCIL

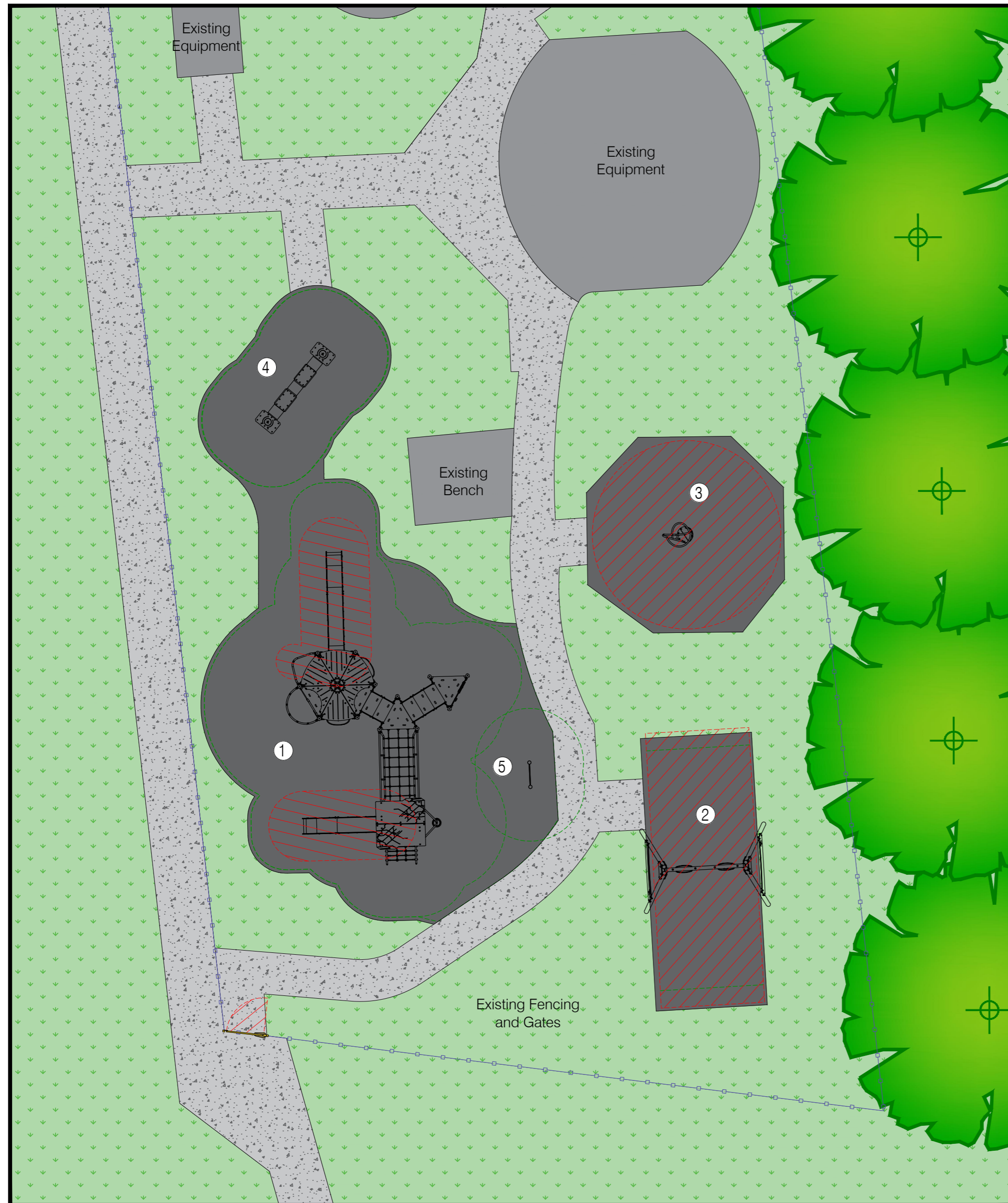

## Awesome New Junior Zone Equipment.

1. Junior Multiplay with, 2x stainless slides with blue HDPE sides, giant tower net, DDA staircase with handgrips, net access, 2x fireman's poles, net bridge, 2x hammocks, play timer panel, roof x2 for shade and inclusive hand grips across all platforms  
PCM310921 - CUSTOM 2027780

DDA Accessible

2. Junior Swings - 2x Flat KSW902 - CUSTOM 20275532

DDA Accessible

3. Rocket

GXY970031-CUSTOM 20275533

DDA Accessible

4. Wave Balance Board

CRP201201-CUSTOM 20275534

DDA Accessible

5. Communication Board

EN-FIPLCO6

DDA Accessible

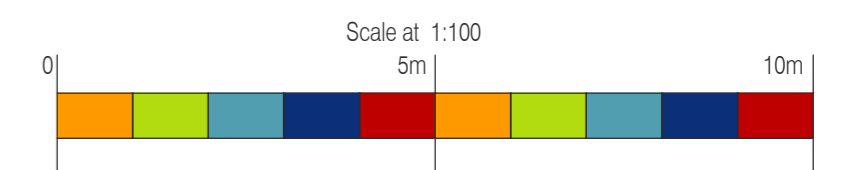
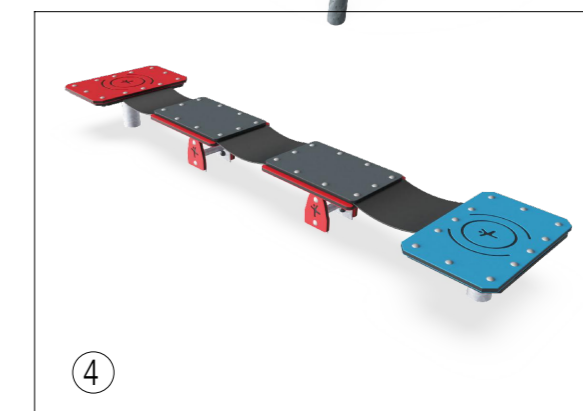
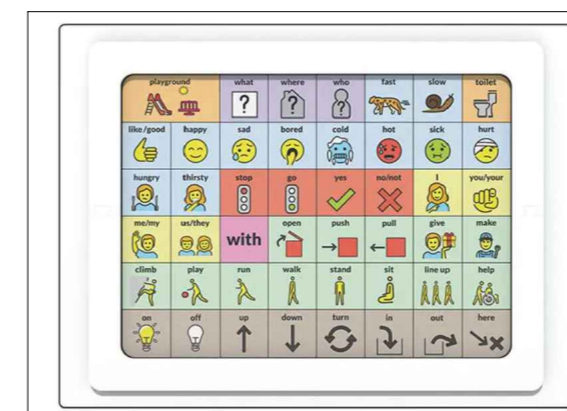
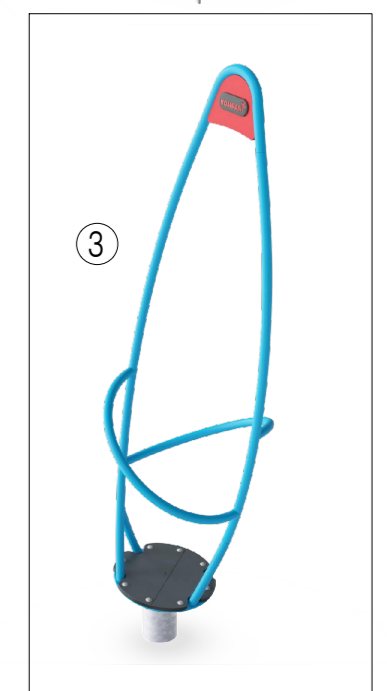
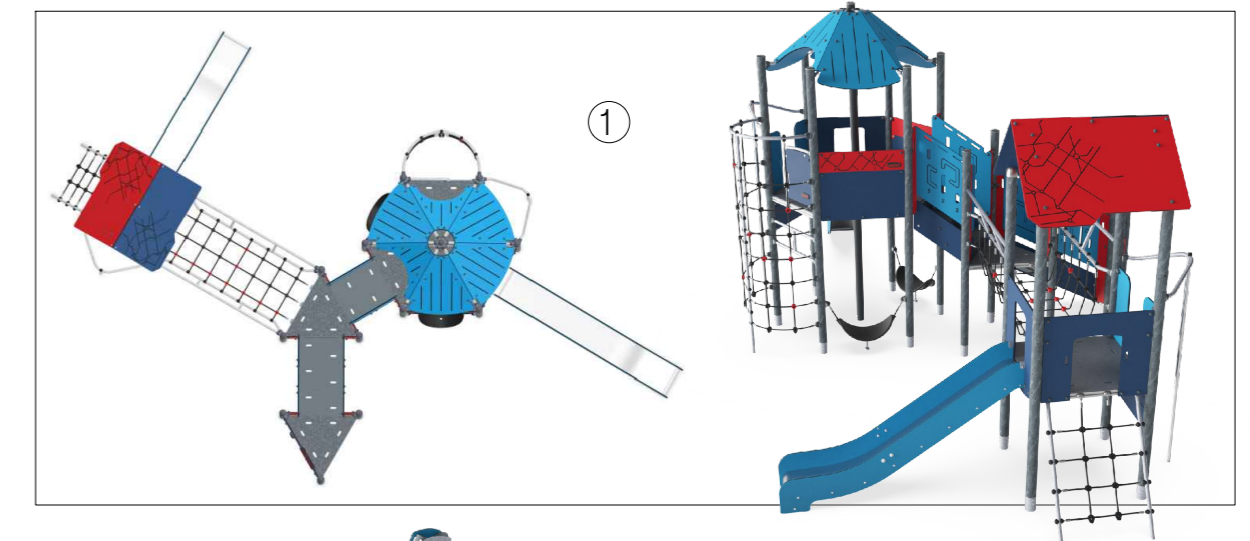

## Surfacing Key:

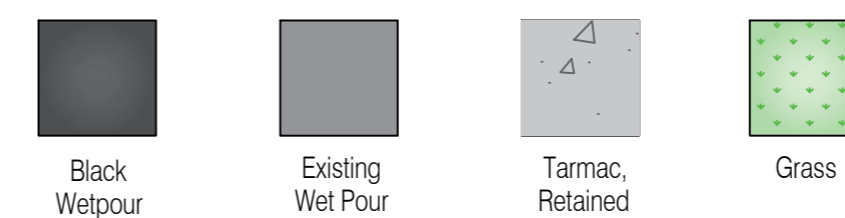

Design assumes the site will be levelled by other (max. gradient 1:100), free draining and with good access

Quotation and design is submitted site unseen, we reserve the right, following a full site survey to amend the design appropriately.

Areas and dimensions shown are critical for compliance with European safety standards En1176 & En1177, If in doubt ask.

Grass areas should be well established prior to grass mat safety surfacing being laid.

**KOMPAN**  
Let's play

KOMPAN Ltd.  
Serenity House  
Milton Keynes  
MK4 1GA

www.KOMPAN.co.uk  
T:01908 201002  
F:01908 201007  
E:KOMPAN.UK@KOMPAN.com

NOT FOR TENDER ISSUE.  
©copyright of this drawing remains the property of KOMPAN Ltd. and the KOMPAN group. This drawing may not be reproduced without prior permission of KOMPAN Ltd.  
Any infringement will be pursued.



Project	WEST_MOLESEY_RECREATION_GROUND	Designed by	R.B
Client	ELMBRIDGE_BOROUGH_COUNCIL	Date	22/03/2024
Drawing No.	CAS-277198-Q2R9F6	Scale	1:100@A2
		Revision	-





Product Sheets

**KOMPAN**  
Let's play



# Triple Tower Stairs

PCM310921



Item no. PCM310921-0904	
General Product Information	
Dimensions LxWxH	855x508x410 cm
Age group	4+
Play capacity (users)	36
Colour options	

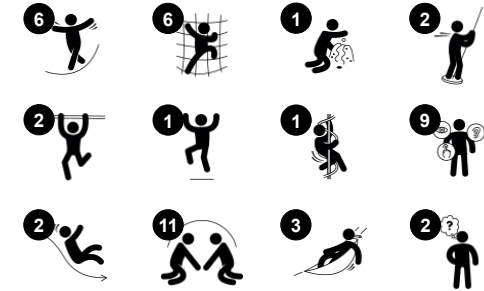

The play unit offers many levels of play: from the inclined climbing net up to the lower platform, from which the child can take the stomach-tickling slide down to the ground or enjoy the rotating movement of the Curly Climber back to the ground. An alternative route is to venture onto the wackle bridge, using the full physical concentration on

balancing to the platform of the stairway. The second half leads to the roomy top of the mega deck, perfect for groups to socialise and play on an elevated level, from which they can choose their way to the ground on either, a curved, bumpy slide or a dare devil pair of banister bars at full speed. An alternative route up to the mega deck platform is up the curved

tower net where climbing will challenge the physical and coordination skills. Under the platform a nice seat and a rocking hammock makes a meeting point for all.



# Triple Tower Stairs Inclusivity



## Tower net

**Physical:** the children have fast access up the horizontal rungs, and a slower climb up the sloping rungs. The net can be climbed from both sides, levelling the challenge. Cross coordination, and arm and leg muscles are trained. **Social-Emotional:** the two-sided net and spaciousness allows for social interaction. **Cognitive:** logical thinking when planning how to best enter the platform from the net.

## Roof

Provides shade and shelter from the elements, creates a sense of enclosure and safety. Turns the play unit into an imaginative house / hotel / school etc.



## Accessible stairway

**Physical:** climbing the accessible stairway is for all and supports cross coordination as well as arm and leg muscles. For young children, walking stairs and alternating feet is developed. **Social-Emotional:** room for active breaks and adult helpers. An inclusive space.



## Wide Moulded Decks with Handholds

Ample space is provided on the decks to enable movement and gathering. Decks have a non-skid pattern and textured surface. Handholds in deck facilitate movement.



## Den Space

Hide and seek, quiet space for a break from play, secret hideaway promoting imaginative play



## Net bridge

**Physical:** walking the open net up or downwards develops balance, spatial awareness and cross coordination. **Social Emotional:** interaction with children outside, socializing. Cooperation and consideration, e.g. when passing others.



## Hammock

**Physical:** coordination and sense of balance when swaying. **Social-Emotional:** meeting, pushing friends gently back and forth, turntaking. **Cognitive:** for toddlers cause and effect understanding.



## Slide

Panel to mouth of slide offers steadiness support at top of slide. **Physical:** sliding develops spatial awareness and a sense of balance. Furthermore, the core muscles are trained when sitting upright going down. **Social-Emotional:** empathy stimulated by turn-taking. **Cognitive:** young children develop their understanding of space, speed and distances when sliding down quickly.



## Fireman's Pole

**Physical:** coordination is supported when going down, as well as arm and core muscles. Landing strengthens bone density, which is built for life in early childhood. **Social Emotional:** turn-taking and risk-taking



# Triple Tower Stairs

PCM310921



Panels of 19mm EcoCore™. EcoCore™ is a highly durable, eco friendly material, which is not only recyclable after use, but also consists of material produced from +95% recycled post consumer material from food packing waste.



All decks are supported by unique designed low-carbon aluminum profiles with multiple attachment options. The grey colored molded decks are made of 75% post-consumer waste PP material with a non-skid pattern and texture surface.



Main posts with hot dip galvanized steel footing are available in different materials: Pressure impregnated pine wood posts. Pre-galvanized inside and outside with powder coated top finish steel posts. Lead free aluminum with color anodized top finish. Greenline TexMade posts of 95% post-consumer recycled PE and textile waste.

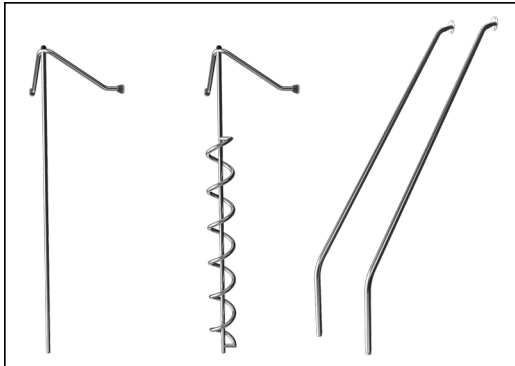

The stainless-steel activities are made of high-quality stainless steel. The steel is cleaned by a total pickling process after manufacturing to ensure a smooth and clean gliding surfaces.



The slides can be chosen in six different colors and tree materials: Straight or curved one-piece molded PE slides, made from 33% recycled post-consumer materials in different colours. Combined EcoCore™ sides and stainless-steel. Full stainless steel in one piece design for more vandalism proof solutions.



KOMPAN GreenLine versions are designed with ultimate environmentally friendly materials with lowest possible CO2e emission factor. TexMade post, EcoCore™ panels of 95% post-consumer recycled waste and molded PP decks.

Item no. PCM310921-0904

### Installation Information

Max. fall height	276 cm
Safety surfacing area	75.7 m <sup>2</sup>
Total installation time	41.5
Excavation volume	1.17 m <sup>3</sup>
Concrete volume	0.27 m <sup>3</sup>
Footing depth (standard)	90 cm
Shipment weight	1,493 kg
Anchoring options	In-ground ✓ Surface ✓

### Warranty Information

EcoCore HDPE	Lifetime
PP Decks	10 years
Post	10 years
Ropes & nets	10 years
Spare parts guaranteed	10 years





# Sustainability Data

PCM310921



Cradle to Gate A1-A3	Total CO <sub>2</sub> emission	CO <sub>2</sub> e/kg	Recycled materials
	kg CO <sub>2</sub> e	kg CO <sub>2</sub> e/kg	%
<b>PCM310921-0951</b>	2,241.70	1.81	70.10
<b>PCM310921-0904</b>	2,702.00	2.55	56.90

The overall framework applied for these factors is the Environmental Product Declaration (EPD), which quantifies "environmental information on the life cycle of a product and enable comparisons between products fulfilling the same function" (ISO, 2006). This follows the structure and applies a Life-Cycle Assessment approach to the entire Product stage from raw material through manufacturing (A1-A3))

**Kompan A/S**  
C.F. Tietgens Boulevard 32C  
DK-5220 Odense SØ  
Denmark



## Verification of CO<sub>2</sub> calculation of: Play systems



Data version no. 2023-10-05

The CO<sub>2</sub> calculation and data are in compliance with the principles of a carbon footprint impact according to the GHG protocol (Greenhouse Gas Protocol), Scope 3, cradle to gate related to all individual components in the product category: "Play systems" represented by item no.: PCM200321-0950.

(Scope 3 emissions include emission sources in the upstream and downstream value chain).

**Date: 30. October 2023 | Valid until: 30. October 2025**

Verified by:

Julie Marie Vejsgaard Larsen, LCA & EPD Consultant

Verification based on report: Validation of CO<sub>2</sub> calculation of 9 categories of Kompan product line, version 1.0, prepared by: Bureau Veritas HSE, Denmark: Julie M. V. Larsen.

**Publication date: 30. October 2023**

By Bureau Veritas HSE  
www.bureauveritas.dk  
+45 7731 1000





# Triple Tower Stairs

PCM310921

\* Max fall height | \*\* Total height | \*\*\* Safety surfacing area

\* Max fall height | \*\* Total height

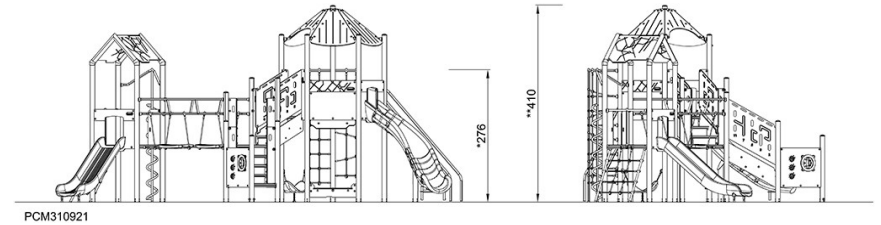
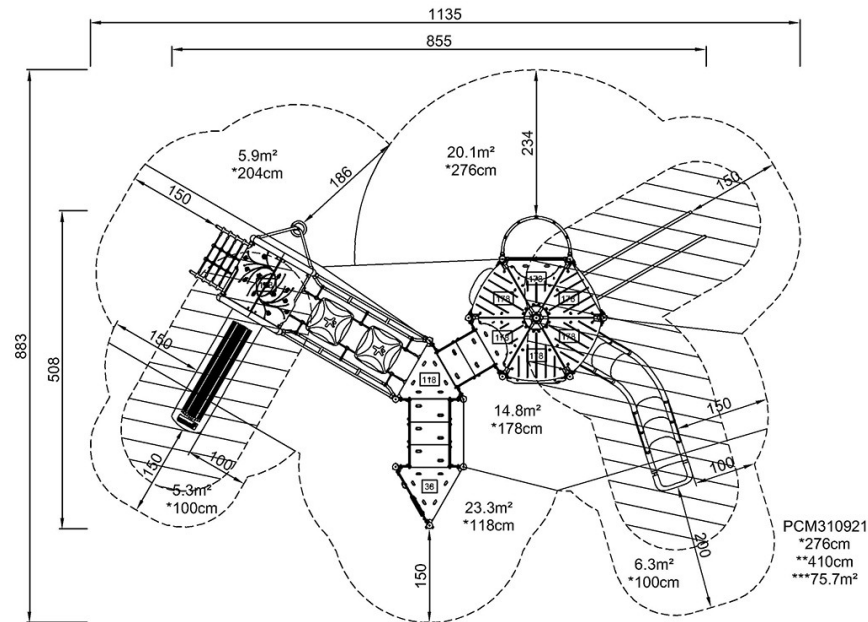

[Click to see TOP VIEW](#)

[Click to see SIDE VIEW](#)



# Swing Frame with 2 x Flat Seats

KSW902

**KOMPAN**  
Let's play



Item no. KSW902-0902	
<b>General Product Information</b>	
Dimensions LxWxH	354x240x274 cm
Age group	2+
Play capacity (users)	-
Colour options	



KOMPAN swings can be configured to adapt individual needs & demands. All A-Frame swings are available in 2,0m and 2,5m height with posts of impregnated pine wood or hot dip galvanized steel. As seats we offer standard swing seat, cradle seat, toddler seat or bird nests with a diameter of ø100cm or 120cm. Further the seats are available with either hot

dip galvanized chains or stainless steel chains and if preferred with antiwrap suspensions. The modular swing system also enable multibay configurations with 2,3,4 or more sections.





# 2-Seat Frame H:2.5m

KSW902



Item no. KSW902-0902

### Installation Information

Total installation time	4.1
Excavation volume	1.30 m <sup>3</sup>
Concrete volume	0.00 m <sup>3</sup>
Footing depth (standard)	90 cm
Shipment weight	109 kg
Anchoring options	In-ground ✓

### Warranty Information

Hot dip galvanised steel	Lifetime
Movable parts	2 years
Spare parts guaranteed	10 years





# Swing Frame with 2 x Flat Seats



## Chains

Robust swing chains offer a comfortable grip.



## Wide Comfortable Seat

At 50.5 x 21.3cm wide, the KOMPAN swing seat is the widest on the market enabling all ages to sit comfortably and allows multiple users to swing together.

Seat height enables easy transfer from pushchair or wheelchair, clearance for legs to dangle without hitting the ground.



## Swinging

**Physical:** balance, coordination and spatial awareness are developed when swinging. These are necessary skills for judging distances and navigating. The swinging movement trains the arm, leg and core muscles, and strengthens bone density when jumping off. **Cognitive:** cause and effect understanding, managing rhythm and thinking skills for younger children when swinging.



# Sustainability Data

KSW902



Cradle to Gate A1-A3	Total CO <sub>2</sub> emission	CO <sub>2</sub> e/kg	Recycled materials
	kg CO <sub>2</sub> e	kg CO <sub>2</sub> e/kg	%
<b>KSW902-0902</b>	208.80	2.04	33.90

The overall framework applied for these factors is the Environmental Product Declaration (EPD), which quantifies "environmental information on the life cycle of a product and enable comparisons between products fulfilling the same function" (ISO, 2006). This follows the structure and applies a Life-Cycle Assessment approach to the entire Product stage from raw material through manufacturing (A1-A3))

**Kompan A/S**  
 C.F. Tietgens Boulevard 32C  
 DK-5220 Odense SØ  
 Denmark



## Verification of CO<sub>2</sub> calculation of: Freestanding play equipment



Data version no. 2023-10-05

The CO<sub>2</sub> calculation and data are in compliance with the principles of a carbon footprint impact according to the GHG protocol (Greenhouse Gas Protocol), Scope 3, cradle to gate related to all individual components in the product category: "Freestanding play equipment" represented by item no.: KSW92011-0910.

(Scope 3 emissions include emission sources in the upstream and downstream value chain).

**Date: 30. October 2023 | Valid until: 30. October 2025**

Verified by:

Julie Marie Vejsgaard Larsen, LCA & EPD Consultant

Verification based on report: Validation of CO<sub>2</sub> calculation of 9 categories of Kompan product line, version 1.0, prepared by: Bureau Veritas HSE, Denmark: Julie M. V. Larsen.

**Publication date: 30. October 2023**

By Bureau Veritas HSE  
 www.bureauveritas.dk  
 +45 7731 1000





# Rocket Roller™

GXY970



Item no. GXY970032-3717	
<b>General Product Information</b>	
Dimensions LxWxH	88x71x248 cm
Age group	6+
Play capacity (users)	2
Colour options	

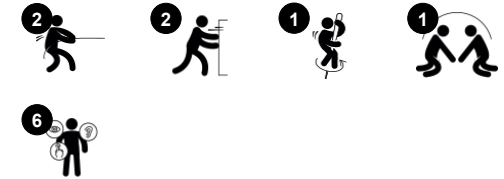

WOW, the Rocket Roller with its intriguing shape attracts children and encourages play again and again. It tickles the stomach, rotates, and encourages children to play together. The shape and possibility to push and pull the tubes invite cooperation. Children can be active together and train empathy, cooperation, and turn-taking skills. The inclination allows children

to adjust the speed with pushing and pulling motions, challenging their proprioception and spatial awareness. Muscles are also developed when holding tight in the fast and fun spin. When rotating, sitting, or standing, children train their sense of balance, which is fundamental for all other motor skills. A well-trained sense of balance helps children

navigate the world securely and is fundamental for being able to sit still and concentrate.

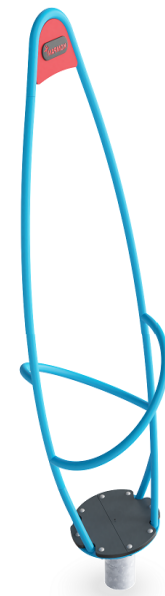



# Rocket Roller™ Inclusivity

## Handholds

**Physical:** the possibility to hold onto more areas of the handhold ensures a good grip, necessary for spinning intensely. This trains hand and arm muscles.

## Rotation

**Physical:** pushing or pulling it into motion, children use their muscle strength and strengthen their cardio. The rotation develops the sense of balance and space when enjoying the ride.

**Social-Emotional:** listening and negotiating how slow or fast to go, children develop their empathy and cooperation skills.



## Internal ball-bearing spinner

**Cognitive:** logical thinking, figuring out how to make the spinner work with gravity, not against it. The bearings are installed in a one-piece design bearing house with integrated drain holes for water passage.

## Rocket Roller

**Physical:** Core and arm muscles and sense of balance and space are trained when using the whole body to start or stop the Rocket Roller's spinning movement. **Social-Emotional:** turn-taking, cooperation and team spirit is supported when spinning standing, seated, together in smaller or bigger groups, and getting dizzy from spinning. **Cognitive:** logical thinking when speeding up or slowing down the spin by different body movements.



# Rocket Roller™

GXY970



The steel surfaces are hot dip galvanised inside and outside with lead free zinc. The galvanisation has excellent corrosion resistance in outside environments and requires low maintenance.



Heavy duty engineered bearing system with single row deep groove ball bearings with rubber seals. The fully closed bearing construction is lifetime lubricated and maintenance free.



Upper plate is made of Ekogrip® panel that consist of a 15mm thick PE base with 3 mm top-layer of soft rubber with a non-skid effect.

Item no. GXY970032-3717

## Installation Information

Max. fall height	100 cm
Safety surfacing area	22.9 m <sup>2</sup>
Total installation time	3.1
Excavation volume	1.00 m <sup>3</sup>
Concrete volume	0.70 m <sup>3</sup>
Footing depth (standard)	100 cm
Shipment weight	121 kg
Anchoring options	



Panels of 19mm EcoCore™. EcoCore™ is a highly durable, eco friendly material, which is not only recyclable after use, but also consists of material produced from +95% recycled post consumer material from food packing waste.



The Rocket Roller is available in three different iconic color concepts. But the roller can also be customized to your preferences and personalized with a variety of Kompan colors, for both the base plate and frame.

**EN**  
**1176**  
compliant



# Sustainability Data

GXY970



Cradle to Gate A1-A3	Total CO <sub>2</sub> emission	CO <sub>2</sub> e/kg	Recycled materials
	kg CO <sub>2</sub> e	kg CO <sub>2</sub> e/kg	%
<b>GXY970032-3717</b>	316.70	3.41	20.30

The overall framework applied for these factors is the Environmental Product Declaration (EPD), which quantifies "environmental information on the life cycle of a product and enable comparisons between products fulfilling the same function" (ISO, 2006). This follows the structure and applies a Life-Cycle Assessment approach to the entire Product stage from raw material through manufacturing (A1-A3))

**Kompan A/S**  
 C.F. Tietgens Boulevard 32C  
 DK-5220 Odense SØ  
 Denmark



## Verification of CO<sub>2</sub> calculation of: Challengers & Climbers

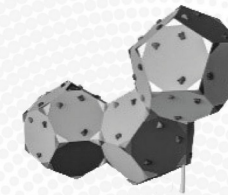

Data version no. 2023-10-05

The CO<sub>2</sub> calculation and data are in compliance with the principles of a carbon footprint impact according to the GHG protocol (Greenhouse Gas Protocol), Scope 3, cradle to gate related to all individual components in the product category: "Challengers & Climbers" represented by item no.: BLX410301-3717.

(Scope 3 emissions include emission sources in the upstream and downstream value chain).

**Date: 30. October 2023 | Valid until: 30. October 2025**

Verified by:

Julie Marie Vejsgaard Larsen, LCA & EPD Consultant

Verification based on report: Validation of CO<sub>2</sub> calculation of 9 categories of Kompan product line, version 1.0, prepared by: Bureau Veritas HSE, Denmark: Julie M. V. Larsen.

**Publication date: 30. October 2023**

By Bureau Veritas HSE  
 www.bureauveritas.dk  
 +45 7731 1000





# Rocket Roller™

GXY970

\* Max fall height | \*\* Total height | \*\*\* Safety surfacing area

\* Max fall height | \*\* Total height

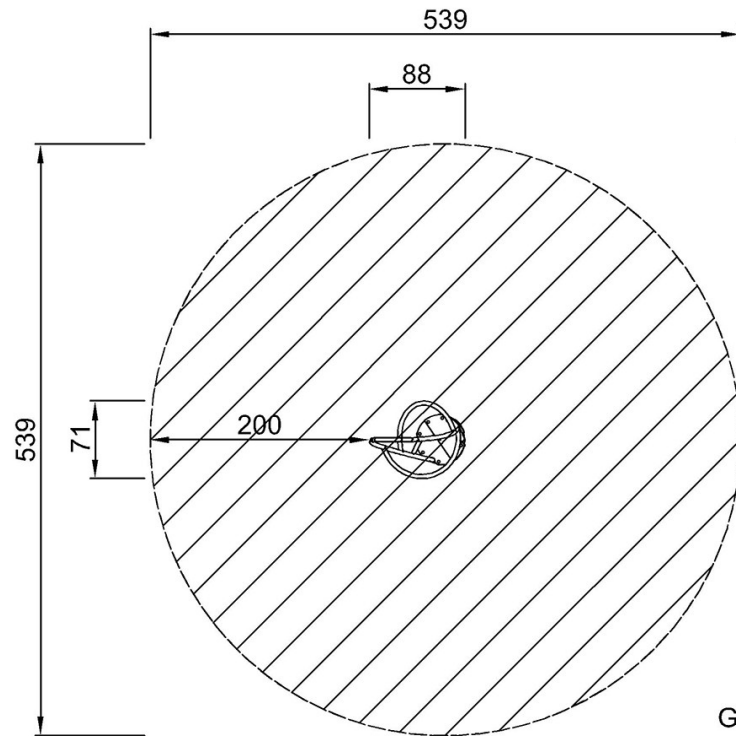

GXY970032  
\*100cm  
\*\*248cm  
\*\*\*22.9m<sup>2</sup>

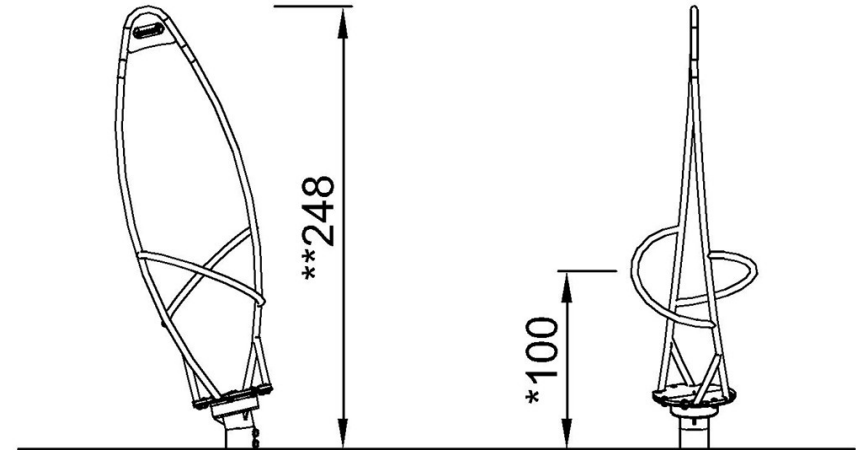

GXY970032

[Click to see TOP VIEW](#)

[Click to see SIDE VIEW](#)



# Wave Stepper

CRP201201



Item no. CRP201201-0401	
<b>General Product Information</b>	
Dimensions LxWxH	290x65x29 cm
Age group	2+
Play capacity (users)	4
Colour options	



The Wave Stepper is a great balancing quest, attracting children and encouraging them to play again and again. Response to the children's movement provides thrill and develops the cause-and-effect understanding; when I move here, the bridge responds with this movement. When walking or running across the Wave Stepper, the children train

their sense of balance, which is a fundamental motor skill and basic for the development of all other skills. The sense of balance for instance makes it possible for children to sit still and concentrate. When children play together on the Wave Stepper, they develop empathy, turn-taking skills, and consideration. The 360-degree design allows for social interaction for

all at ground level.



Data is subject to change without prior notice.



# Wave Stepper Inclusivity

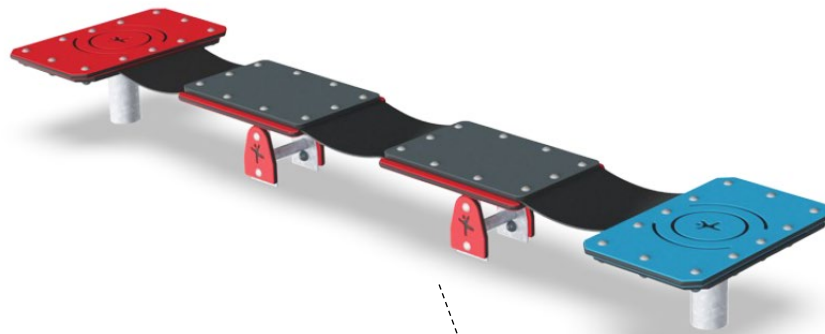

## Wave Stepper

**Physical:** trains the sense of balance, fundamental for all other motor skills. This builds children's ability to navigate their bodies confidently and securely through the world.

**Social-Emotional:** turn-taking skills and negotiation when crossing each other and seating, standing, jumping. **Cognitive:** supports cause-and-effect understanding when the steps slightly tilt in accordance with the children's movements.



# Wave Stepper

CRP201201



Corocord membranes consist of friction-proof rubberized material of conveyor belt quality with excellent UV resistance. Tested and compliant with REACH requirements for PAH. Embedded is a four-layered armoring made of woven polyester. The armoring and the two surface layers result in a total thickness of 8 mm.



Panels of 19mm EcoCore™. EcoCore™ is a highly durable, eco friendly material, which is not only recyclable after use, but also consists of material produced from +95% recycled post consumer material from food packing waste.



The two central plates on the Wave Stepper are of made of Ekogrip® panels that consist of a 15mm thick PE base with 3 mm top-layer of soft rubber with a non-skid effect.

Item no. CRP201201-0401

### Installation Information

Max. fall height	28 cm
Safety surfacing area	19.3 m <sup>2</sup>
Total installation time	4.9
Excavation volume	1.73 m <sup>3</sup>
Concrete volume	0.96 m <sup>3</sup>
Footing depth (standard)	90 cm
Shipment weight	132 kg
Anchoring options	



The bushings are made of stainless steel or galvanized steel to ensures excellent shock absorption and durable connections with a high corrosion resistance.



The steel surfaces are hot dip galvanized inside and outside with lead free zinc. The galvanisation has excellent corrosion resistance in outside environments and requires low maintenance.

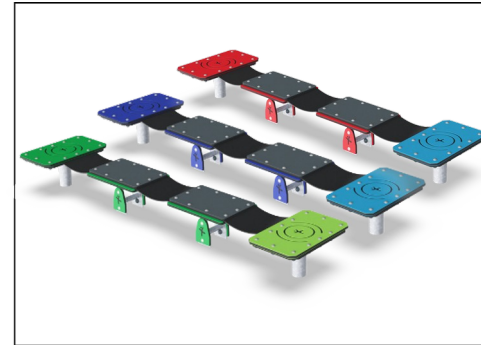

The Wave Stepper comes in three different iconic color concepts. But the Stepper can also be customized to your preferences and personalized with a variety of Kompan colors, for both the base plates and footing.

**EN  
1176**  
compliant



# Sustainability Data

CRP201201

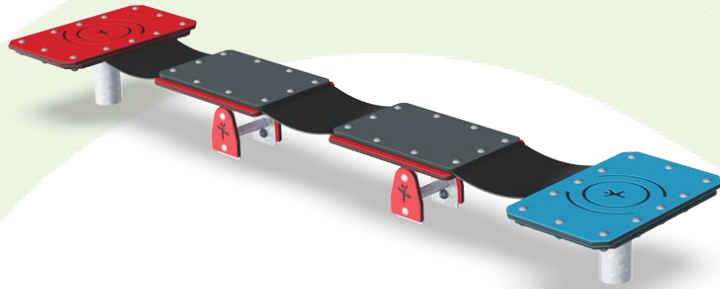

Cradle to Gate A1-A3	Total CO <sub>2</sub> emission	CO <sub>2</sub> e/kg	Recycled materials
	kg CO <sub>2</sub> e	kg CO <sub>2</sub> e/kg	%
<b>CRP201201-0401</b>	233.40	2.33	57.10

The overall framework applied for these factors is the Environmental Product Declaration (EPD), which quantifies "environmental information on the life cycle of a product and enable comparisons between products fulfilling the same function" (ISO, 2006). This follows the structure and applies a Life-Cycle Assessment approach to the entire Product stage from raw material through manufacturing (A1-A3))

**Kompan A/S**  
 C.F. Tietgens Boulevard 32C  
 DK-5220 Odense SØ  
 Denmark



## Verification of CO<sub>2</sub> calculation of: Corocord



Data version no. 2023-10-05

The CO<sub>2</sub> calculation and data are in compliance with the principles of a carbon footprint impact according to the GHG protocol (Greenhouse Gas Protocol), Scope 3, cradle to gate related to all individual components in the product category: "Corocord" represented by item no.: COR314011-1101.

(Scope 3 emissions include emission sources in the upstream and downstream value chain).

**Date: 30. October 2023 | Valid until: 30. October 2025**

Verified by:

Julie Marie Vejsgaard Larsen, LCA & EPD Consultant

Verification based on report: Validation of CO<sub>2</sub> calculation of 9 categories of Kompan product line, version 1.0, prepared by: Bureau Veritas HSE, Denmark: Julie M. V. Larsen.

**Publication date: 30. October 2023**

By Bureau Veritas HSE  
 www.bureauveritas.dk  
 +45 7731 1000





# Wave Stepper

CRP201201

\* Max fall height | \*\* Total height | \*\*\* Safety surfacing area

\* Max fall height | \*\* Total height

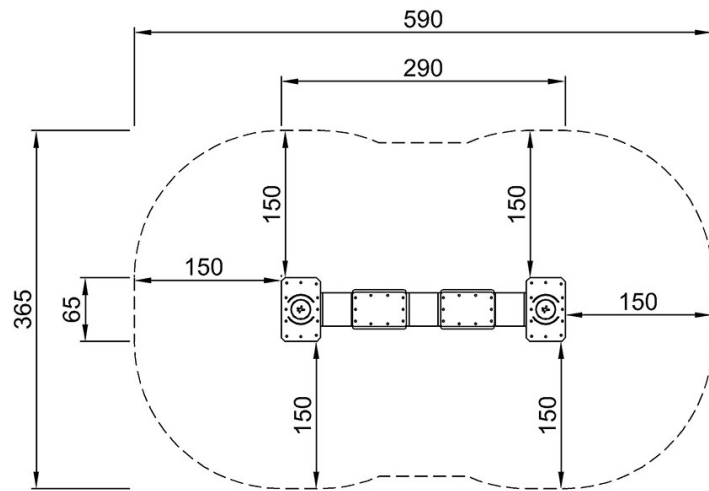

CRP201201  
\*28cm  
\*\*29cm  
\*\*\*19.3m<sup>2</sup>

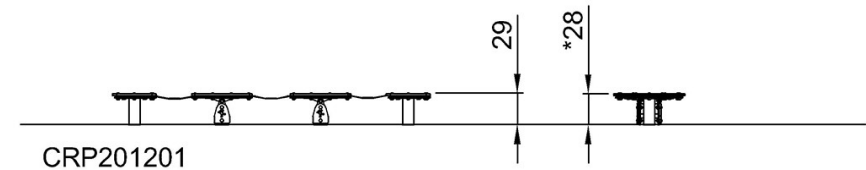

[Click to see TOP VIEW](#)

[Click to see SIDE VIEW](#)



# Product Information

## FIPLCO6 - Playground Communication Panel

BS EN 1176 - Designed to British & European Standards

### MATERIALS

Panel - Two Colour  High Density Polyethylene (HDPE)

### SUPPLY METHOD

Panel - Singular panel

### FEATURES



**INCLUSIVE** - Accessible activity and panel height



**SOCIAL** - Communication through images



### DIMENSIONS

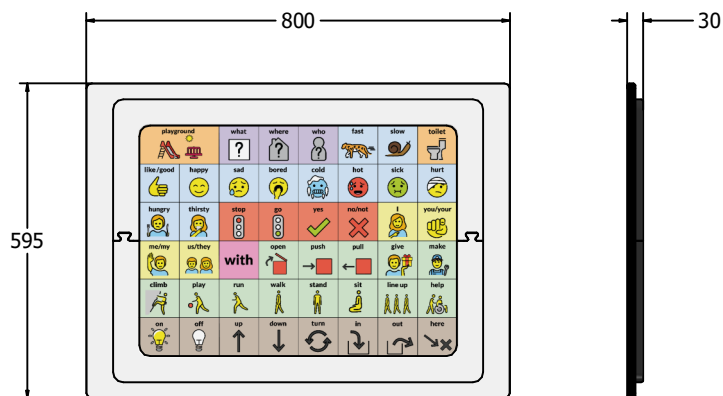

FIPLCO6  
FIPLCO6-AL-WP

Standard Panel  
Panel with Alu Posts

### TECHNICAL

Age Range: 2+ Years  
Largest Part: 595 x 800 x 30mm  
Total Weight: 9.3kg  
Surfacing: N/A

IMPORTANT: you must specify the colour option you require at the time of order if it is different from the colour listed/shown above, requirements are subject to availability at the time of order





**Vandalism (1.2.3.1) & (2.12)**



# Resistance to Vandalism

At KOMPAN, we understand the upset, frustration and expense that will result from vandalism of an outdoor play, sport and fitness site, so we suggest a six-step model that will improve the success of the site in terms of providing resistance to vandalism.

Many play companies will focus on reducing the effect of vandalism and only talk about material strength and spare parts, but at KOMPAN we also focus on the reducing the cause through the first four stages of consultation, location, design and engagement.

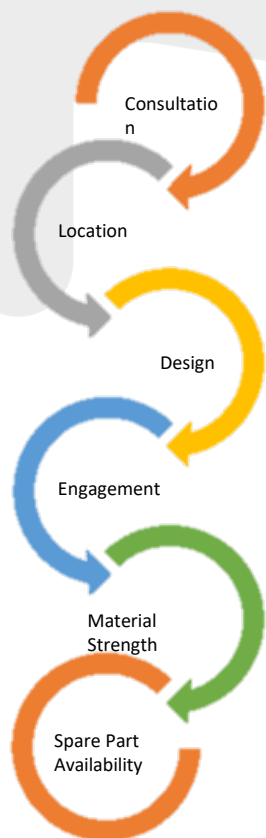

## Consultation

Involving the community from the start and understanding their needs will give the project a far greater chance of engagement and ownership once the playground is completed and handed over. Talk to KOMPAN about how we can help.

## Location

A location with good visibility into the site from as many sides as possible is preferred; the more eyes and people watching, the less chance of anti-social behaviour.

## Design

Our designer will work with you to design in transparency of the equipment, limit the potential for damage and graffiti and direct children to preferred hang out areas. The use of lighting and cameras may be considered if budget allows.

## Engagement

A community that loves the playground are more likely to informally police the area and report anti-social behaviour sooner rather than later, Community engagement throughout the process is key and an opening event will bring everyone together.

## Material Strength

Our designer will work with you to ensure the best fit material solution for you project

## Spare Part Availability

A rapid response to damaged or worn-out equipment will reduce the frustration and potential for further anti-social behaviour caused by out of service equipment.



# Resistance to Vandalism

KOMPAN Playgrounds must withstand the wear and tear of weather, heavy usage, and vandalism. Using the highest quality materials that need minimum maintenance, our play spaces look great for decades, and therefore are heavily used, which means it helps deter vandals, as most vandalism occurs when play spaces are little used or look unkept.

To help reduce the risk of vandalism and theft KOMPAN have examined as many ways as possible to introduce measures that also reduce on going replacement costs throughout the lifetime of the equipment.

Included in the measures are: -

- ✦ Bolt connections are secured and covered with tamper proof infill caps designed to fit within our fixings and require a special KOMPAN tool (supplied with the product) for removal of the fixing.
- ✦ Uncovered bolt connections are provided with special anti-theft torx applications which can only be loosened with special tools ensuring you have tamper/vandal proof fittings.
- ✦ Ropes are more robust than other manufacturers as within the rope, are galvanized 6 stranded steel wires and steel core, impossible to wear through. Each strand is wrapped in PES yarn which is then melted onto each strand making each rope highly vandalism resistance.
- ✦ Play Panels are made of EcoCore which is a highly vandal resistant material against breaking or if scratched the colour is not affected. Maximum UV protection prevents fading in the sun.
- ✦ KOMPAN basket seats are designed with vandalism in mind. Most existing seats provided in the market have edges and baskets wrapped in rope which are notorious for being unraveled or burnt, whereas KOMPAN Shell Nest seat have a solid structure and edges.
- ✦ All KOMPAN swings have Anti Twist mechanisms as standard, “the only company to do this”, to stop vandals twisting seats to make them higher and over time causing damage to the seats and chains. Anti-Wrap bearings can also be fitted, which helps reduce to damage to the cross bar when seats and chains are wrapped around them.
- ✦ HPL Decks are 18mm thick. This thickness makes the decks stronger and helps stop breakages through vandalism.
- ✦ Equipment that has a Powder Coated finish has Galvanised steel so should the powder coat surface be damaged through vandalism; the risk of rusting is greatly reduced.
- ✦ You will find lot of posts, spindles, handrails, bars, seat frames etc. are constructed using galvanized round bar, or tubing. This is because it makes components stronger and able to withstand Vandalism better.





**Colour Options 2.5**



# Colour options

Within our proposal we will supply the below equipment which has multiple colour options you are able to choose from.

